

2-way Diaphragm Control Valve, cast stainless steel body, pneumatically operated, port connection DN 15-50



- The perfect control valve for highest demands
- Hermetical separation of fluids from operator mechanism by diaphragm
- Self draining and zero dead volume
- Suitable for hygienic applications, conform to FDA/USP

Type 2731 can be combined with...



Type 8692/8693
Positioner / Process Controller TopControl



Type 8694
Positioner TopControl Basic



Type 8635
Positioner SideControl



Type 8792/93
SideControl Remote-Versions



Type 8030
Flow sensor

The diaphragm control valve Type 2731 consists of a pneumatically operated piston actuator, a diaphragm and a valve body made of investment cast stainless steel.

The actuator has been designed so that the stroke can be continuously changed. This makes a favourable characteristic possible for the continuous change of the flow.

The Type 2731 can be actuated by the 8635 SideControl, SideControls 8792/93 Remote versions or the 8694/8692/8693 TopControl forming a mechanical and functional unit and thus offering a complete control valve system. Using this control valve, continuous regulation tasks for fluids can be solved.

Proven Applications

- Water treatment
- Biotechnology
- Food industry

Technical data		
Materials	Body Actuator	Cast stainless steel 316L/1.4435 PA polyamide (PPS on request)
Diaphragm materials		EPDM (AB), PTFE/EPDM (EA) EPDM (AD), advanced PTFE/EPDM (EU) and FKM (FF) on request
Process medium		For neutral gases and liquids, high purity, sterile aggressive or abrasive fluids
Viscosity		Up to viscous
Surface finish	internal mechanical polished (external cast surface) <i>On request</i> internal electro polished (external cast surface electro polished)	(average surface finish) Ra ≤ 0.8 µm Ra ≤ 0.6 µm
Medium temperature	EPDM (AB), PTFE/EPDM (EA) EPDM (AD), advanced PTFE/EPDM (EU) FKM (FF)	-10 to + 130 °C (steam sterilisation +140 °C for 60min) -5 to +143 °C (steam sterilisation +150 °C for 60min) 0 to +130 °C (not recommended for steam)
Ambient temperature		-10 to +60 °C
Control medium	(for coupling with a positioner)	Instrumental air class 3 acc. to DIN ISO 8573-1
Pilot pressure		5.5 to 7 bar with actuator sizes Ø80 to 125 mm
Pilot air ports		G1/4 (stainless steel)
Flow characteristic		See chart p. 2

Content

Valve specifications	System Continuous CLASSIC	Request for quotation
Type 2731 cast	Type 8802-DD	Type 8802-DD
Technical data & ordering info. p. 1-5	Ordering info. & technical data p.6-11	p.12-14

Technical data, *continued*

Technical data	
Port connections	
Weld end acc. to	EN ISO 1127/ISO 4200, DIN 11850 S2 (on request SMS 3008, ASME BPE, DIN 11850 S 0, 1, 3, JIS and BS 4825)
On request clamp	DIN 32676, ISO 2852/SMS 3017, BS 4825
Installation	As required, preferably with actuator in upright position

Kvs values and weights

Port connection DN [mm]	Actuator size [mm]	Kvs value [m ³ /h]	Weight without positioner [kg]
15	80	4.5	1.9
20	80	7.5	2.0
25	80	12.0	2.2
40	125	30.0	6.9
50	125	51.5	7.6

Flow characteristic

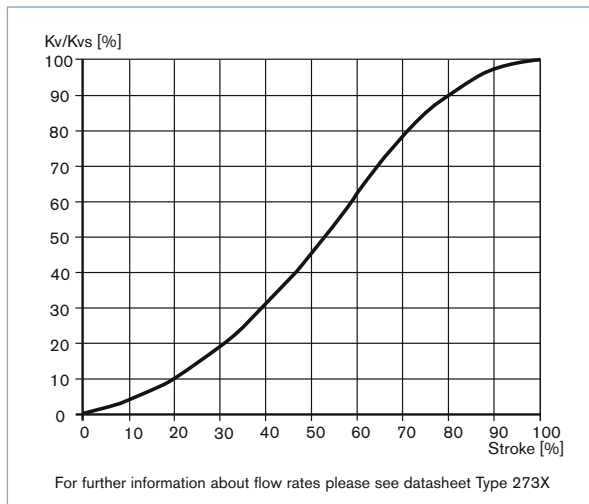

Installation for self-draining operation

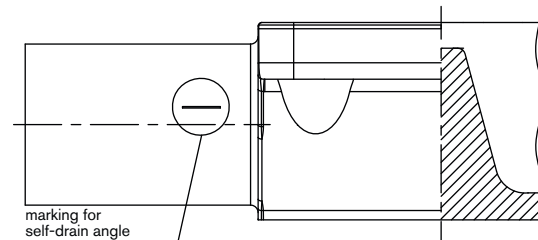
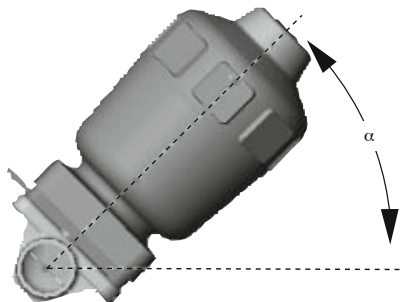

$\alpha = 15^\circ$ up to 35° (Marking must face upwards, 12 o'clock position)
 plus 1° to 5° inclination to the pipe axis.
 Drain marks permanently marked on both sides of the valve body
 show the correct mounting position to optimise drain ability.

Materials

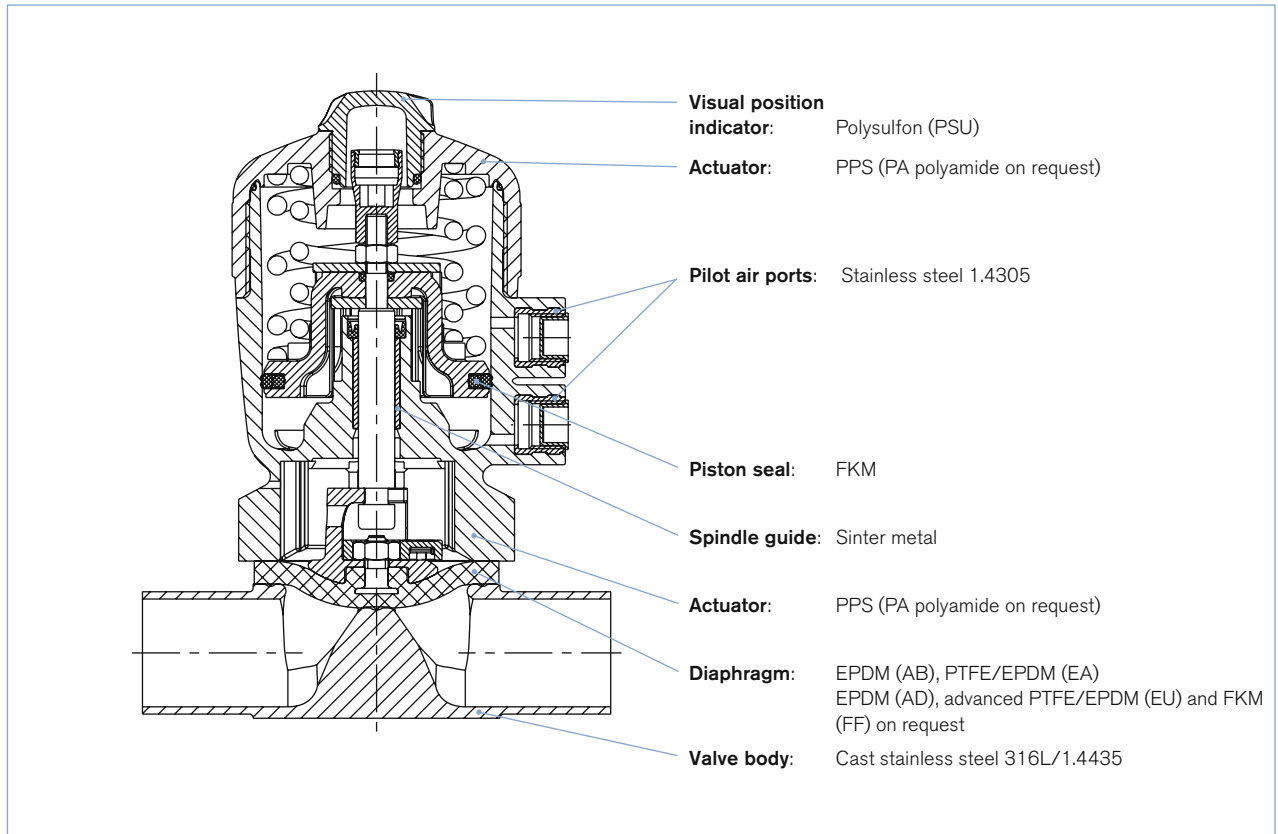

Approvals/certifications

Suitability for foodstuffs / sterile applications



- The composition of the EPDM (AB), EPDM (AD), PTFE/EPDM (EA) and advanced PTFE (EU) diaphragms corresponds to the Code of Federal Regulations, published by the FDA (Food and Drug Administration, USA).





- The composition of the EPDM (AB), EPDM (AD), PTFE/EPDM (EA) and advanced PTFE (EU) diaphragms is suitable for the application with food and beverage (acc. to EC-Regulation 1935/2004/EC)
- The composition of the EPDM (AB), EPDM (AD), PTFE/EPDM (EA) and advanced PTFE (EU) diaphragms are approved acc. USP Class VI
- Approval according to TA-air (Port size DN4-50)

Ordering chart valve

Weld end acc. to EN ISO 1127/ISO 4200

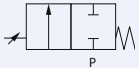
PA actuator, internal mechanical polished, external cast surface; average surface internal 0.8 µm

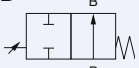
Control function	Port connection DN [mm]	Actuator size Ø [mm]	Kvs value [m ³ /h]	Operating pressure max. ¹⁾ [bar]	Item no.
EN ISO 1127/ISO 4200					
EPDM diaphragm material (AB)					
A  NC by spring return	15	80	4.5	10	550 425
	20	80	7.5	10	550 429
	25	80	12	10	550 431
	40	100	30	6.5	550 433
	50	125	51.5	8	550 435
B  NO by spring return	15	80	4.5	10	550 437
	20	80	7.5	10	550 439
	25	80	12	10	550 441
	40	100	30	10	550 443
	50	125	51.5	7	550 445
PTFE/EPDM diaphragm material (EA)					
A  NC by spring return	15	80	4.5	10	550 426
	20	80	7.5	10	550 430
	25	80	12	7.5	550 432
	40	100	30	6	550 434
	50	125	51.5	7	550 436
B  NO by spring return	15	80	4.5	9	550 438
	20	80	7.5	8.5	550 440
	25	80	12	8	550 442
	40	100	30	10	550 444
	50	125	51.5	4	550 446

¹⁾ with a pilot pressure of 5.5 bar
 Further versions on request
**Material**

Actuator: PPS
 Diaphragms EPDM (AD) and advanced PTFE/EPDM (EU) for steam sterilisation, FKM (FF)

**Port connection**

Welded body acc. to SMS 3008, ASME BPE, DIN 11850 S0, 1, 3, JIS and BS4825
 Clamp body acc. to DIN 32676, ISO 2852/SMS 3017, BS 4825

**Additional**

Surface finish internal electro polished (external cast surface electro polished), Ra ≤ 0.6 µm

Ordering chart valve

Weld end acc. to DIN 11850 Series 2

PA actuator, internal mechanical polished, external cast surface; average surface internal 0.8 µm

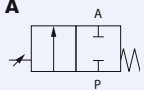
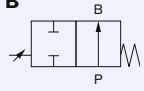
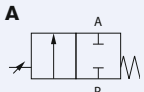
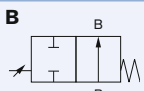
Control function	Port connection DN [mm]	Actuator size Ø [mm]	Kvs value [m³/h]	Operating pressure max. ¹⁾ [bar]	Item no.
DIN 11850 Series 2					
EPDM diaphragm material (AB)					
A  NC by spring return	15	80	4.5	10	550 447
	20	80	7.5	10	550 451
	25	80	12	10	550 453
	40	100	30	6.5	550 454
	50	125	51.5	8	550 456
B  NO by spring return	15	80	4.5	10	550 458
	20	80	7.5	10	550 460
	25	80	12	10	550 462
	40	100	30	10	550 464
	50	125	51.5	7	550 466
PTFE/EPDM diaphragm material (EA)					
A  NC by spring return	15	80	4.5	10	550 448
	20	80	7.5	10	550 452
	25	80	12	7.5	153 330
	40	100	30	6	550 455
	50	125	51.5	7	550 457
B  NO by spring return	15	80	4.5	9	550 459
	20	80	7.5	8.5	550 461
	25	80	12	8	550 463
	40	100	30	10	550 465
	50	125	51.5	4	550 467

¹⁾ with a pilot pressure of 5.5 bar
 Further versions on request
**Material**

Actuator: PPS
 Diaphragms EPDM (AD) and advanced PTFE/EPDM (EU) for steam sterilisation, FKM (FF)

**Port connection**

Welded body acc. to SMS 3008, ASME BPE, DIN 11850 S0, 1, 3, JIS and BS4825
 Clamp body acc. to DIN 32676, ISO 2852/SMS 3017, BS 4825

**Additional**

Surface finish internal electro polished (external cast surface electro polished), Ra ≤ 0.6 µm

Ordering information for valve system Continuous CLASSIC Type 8802-DD

A valve system Continuous CLASSIC Type 8802-DD consists of an diaphragm control valve Type 2731 and a digital electropneumatic Positioner Type 8692, a digital electropneumatic Process Controller Type 8693, a digital electropneumatic Positioner Basic Type 8694 (below) or a SideControl Type 8635 or an electropneumatic positioner Type 8792/8793 (next page) (see separate datasheets).

For the configuration of further valve systems please use the "Request for quotation" on p. 12 [go to page](#)

You order two components and receive a complete assembled and certified valve.

Ordering the valve system Continuous CLASSIC Type 8802-DD

Diaphragm control valve Type 2731



Positioner



Positioner
Type 8692



Process Controller
Type 8693



Positioner Basic
Type 8694

Diaphragm control valve with desired positioner



Valve system
Continuous
CLASSIC
Type 8802-DD-L
2731 + 8694



Valve system
Continuous
CLASSIC
Type 8802-DD-I
2731 + 8692



Valve system
Continuous
CLASSIC
Type 8802-DD-J
2731 + 8693

Positioner TopControl Type 8692

More info.



Process Controller TopControl Type 8693

More info.



Positioner TopControl Basic Type 8694

More info.



The new generation of integrated positioners/process controllers for combination with actuators from the process valve series Type 23xx/2103 is specially designed for the requirements of hygienic process environments. The easy handling and the selection of additional software functions are done either on a big graphic display with backlight and keypad or via a PC interface. A contact-free analogue position sensor registers the valve position without deterioration. Single-acting or double-acting actuators are controlled via the integral positioner system. With Type 8693, the process controller function is superimposed on the position control loop. Profibus DPV1 and DeviceNet communication interfaces are available as options.

Main customer benefits:

- Compact design of the valve system with integrated positioner/process controller meets the demands for plant washdown environments through the selection of materials, external seals and integrated control air supply to the actuator
- Extremely simple commissioning and operation thanks to the back-lighting of the graphics display and proven multilingual software structure
- Automatic parameterisation of the positioner and process controller using the TUNE functions
- Field bus communication via Profibus DPV1 or DeviceNet
- Air intake filter enhances the process valve system availability
- Simple and reliable actuator adaption
- Explosion-proof models for zone 2/22

The new generation of integrated positioners for combination with actuators from the process valve series Type 23xx/2103 is specially designed for the requirements of hygienic process environments. The operation and selection of the software functions close tight function, inversion of the operating direction of the setpoint signal, characteristic curves selection and switching manual/automatic operation are effected via push-buttons and DIP switches or via the PC interface. The position setpoint is set using the standard signal 4 - 20 mA. In addition, the enable can be controlled via the binary input and an optional position feedback can be integrated. The positioner, Type 8694, registers the valve position without deterioration through a contact-free analogue position sensor. Single-acting or double-acting actuators are controlled via the integral positioner system. An AS-Interface communication interface is available as an option.

Main customer benefits:

- Compact design of the valve system with integrated positioner meets the demands for plant washdown environments through the selection of materials, external seals and integrated control air supply to the actuator
- Automatic parameterisation of the process controller using the Process TUNE function
- Field bus communication via optional AS-Interface
- Air intake filter enhances the process valve system availability
- Simple and reliable actuator adaption allowing additional actuators of the process valve series, Type 20xx or actuators from other manufacturers to be used
- Explosion-proof models for zone 2/22

Click on the orange box "More info"... you will come to our website for the resp. product where you can download the data sheet.

Ordering information for valve system Continuous CLASSIC Type 8802-DD, *continued*

A valve system Continuous CLASSIC Type 8802-DD consists of an diaphragm control valve Type 2731 and a digital electropneumatic Positioner Type 8692, a digital electropneumatic Process Controller Type 8693, a digital electropneumatic Positioner Basic Type 8694 (previous page) or a SideControl Type 8635 or an electropneumatic positioner Type 8792/8793 (below) (see separate datasheets).

For the configuration of further valve systems please use the "Request for quotation" on p. 12 [go to page](#)

You order two components and receive a complete assembled and certified valve.

Ordering the valve system Continuous CLASSIC Type 8802-DD

Diaphragm control valve
Type 2731

Positioner



Positioner/
Process Controller
Type 8635



Positioner Type 8792
Process Controller Type 8793

Diaphragm control valve
with desired positioner



Valve system
Continuous CLASSIC
Type 8802-DD-B
2731 + 8635



Valve system
Continuous CLASSIC
Type 8802-DD-P
2731 + 8792 /
Type 8802-DD-Q
2731 + 8793

SideControl Type 8635, 2-wire,
intrinsically safe

More info.



4-20 mA



Type 8635 is a digital electro-pneumatic positioner with an optional, integrated process controller for precise control requirements. The compact design with integrated position encoder and LCD display was developed for demanding applications of the process industry.

Main customer benefits are:

- Time saving algorithms for temperature, flow and pressure PID parameters through ProcessTUNE function.
- Quick and simple menu driven parameterization through keyboard or Profibus PA
- Remote setpoint adjustment via a 4-20 mA signal
- Adaptation according to IEC534-6 for lift and swivel drives
- Rugged anodised aluminium housing
- Suitable for hazardous locations per zone 1, zone 21 or zone 2 and 22

Positioner SideControl Type 8792

More info.

Process Controller SideControl Type 8793

More info.



Type 8792/8793 is a digital electro-pneumatic positioner with an optional, integrated process controller (8793) for precise control requirements. The compact design with integrated position encoder and LCD display was developed for demanding applications of the process industry. A Profibus DPV1 communication interface is available as an option.

Main customer benefits are:

- Time saving algorithms for temperature, flow and pressure PID parameters through ProcessTUNE function.
- Quick and simple menu driven parameterization through keyboard or Profibus DPV1 PA
- Adaption acc. to IEC534-6 and VDI/VDE 3845 for lift and swivel drives or as a Remote version together with Bürkert process valves
- Rugged anodised aluminium housing
- Suitable for hazardous locations per zone 2/22

Click on the orange box "More info"... you will come to our website for the resp. product where you can download the data sheet.

Dimensions for valve system Continuous CLASSIC Type 8802-DD [mm]

Dimensions valve system Continuous CLASSIC Type 8802-DD-I with positioner TopControl Type 8692 and 8802-DD-J with process controller TopControl Type 8693 [mm]

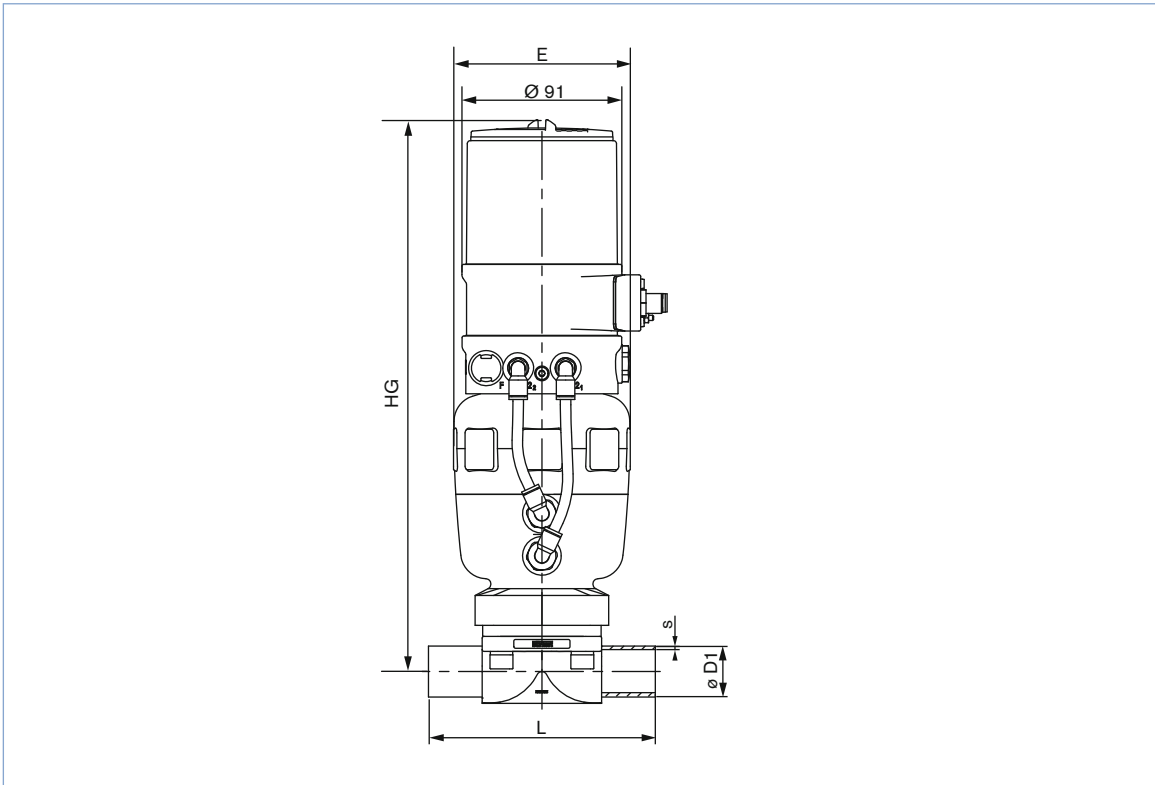

Port connection [mm]	Actuator size [mm]	E	HG [mm]	L	EN ISO 1127/ ISO 4200		DIN 11850								SMS 3008		JIS (on request)	
					Series 0		Series 1		Series 2		Series 3		D1	s	D1	s		
					D1	s	D1	s	D1	s	D1	s						
15	80	101	300	110	21.3	1.6	18	1.5	18	1	19	1.5	20	2	-	-	21.7	2.1
20	80	101	313	119	26.9	1.6	22	1.5	22	1	23	1.5	24	2	-	-	27.2	2.1
25	80	101	316	129	33.7	2	28	1.5	28	1	29	1.5	30	2	25	1.2	25.4	1.2
40	125	153	408	161	48.3	2	40	1.5	40	1	41	1.5	42	2	38	1.2	38.1	1.2
50	125	153	414	192	60.3	2	52	1.5	52	1	53	1.5	54	2	51	1.2	50.8	1.5

Dimensions for valve system Continuous CLASSIC Type 8802-DD [mm], *continued*

Dimensions valve system Continuous CLASSIC Type 8802-DD-L with positioner TopControl Basic Type 8694 [mm]

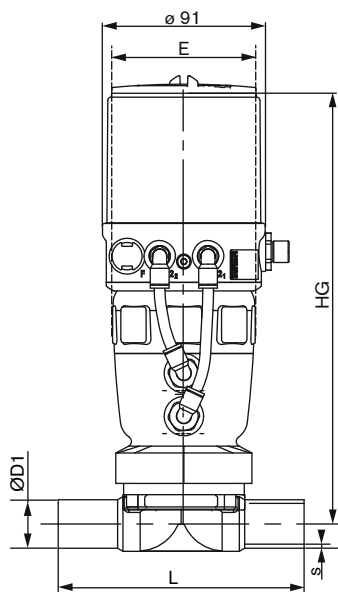

Port connection [mm]	Actuator size [mm]	E	HG [mm]	L	EN ISO 1127/ ISO 4200		DIN 11850				SMS 3008				JIS (on request)					
					Series 0		Series 1		Series 2		Series 3		D1		s		D1		s	
					D1	s	D1	s	D1	s	D1	s	D1	s	D1	s	D1	s	D1	s
15	80	101	260	110	21.3	1.6	18	1.5	18	1	19	1.5	20	2	-	-	21.7	2.1		
20	80	101	270	119	26.9	1.6	22	1.5	22	1	23	1.5	24	2	-	-	27.2	2.1		
25	80	101	273	129	33.7	2	28	1.5	28	1	29	1.5	30	2	25	1.2	25.4	1.2		
40	125	153	366	161	48.3	2	40	1.5	40	1	41	1.5	42	2	38	1.2	38.1	1.2		
50	125	153	372	192	60.3	2	52	1.5	52	1	53	1.5	54	2	51	1.2	50.8	1.5		

Dimensions for valve system Continuous CLASSIC Type 8802-DD [mm], *continued*

Dimensions valve system Continuous CLASSIC 8802-DD-B with positioner SideControl Type 8635 [mm]

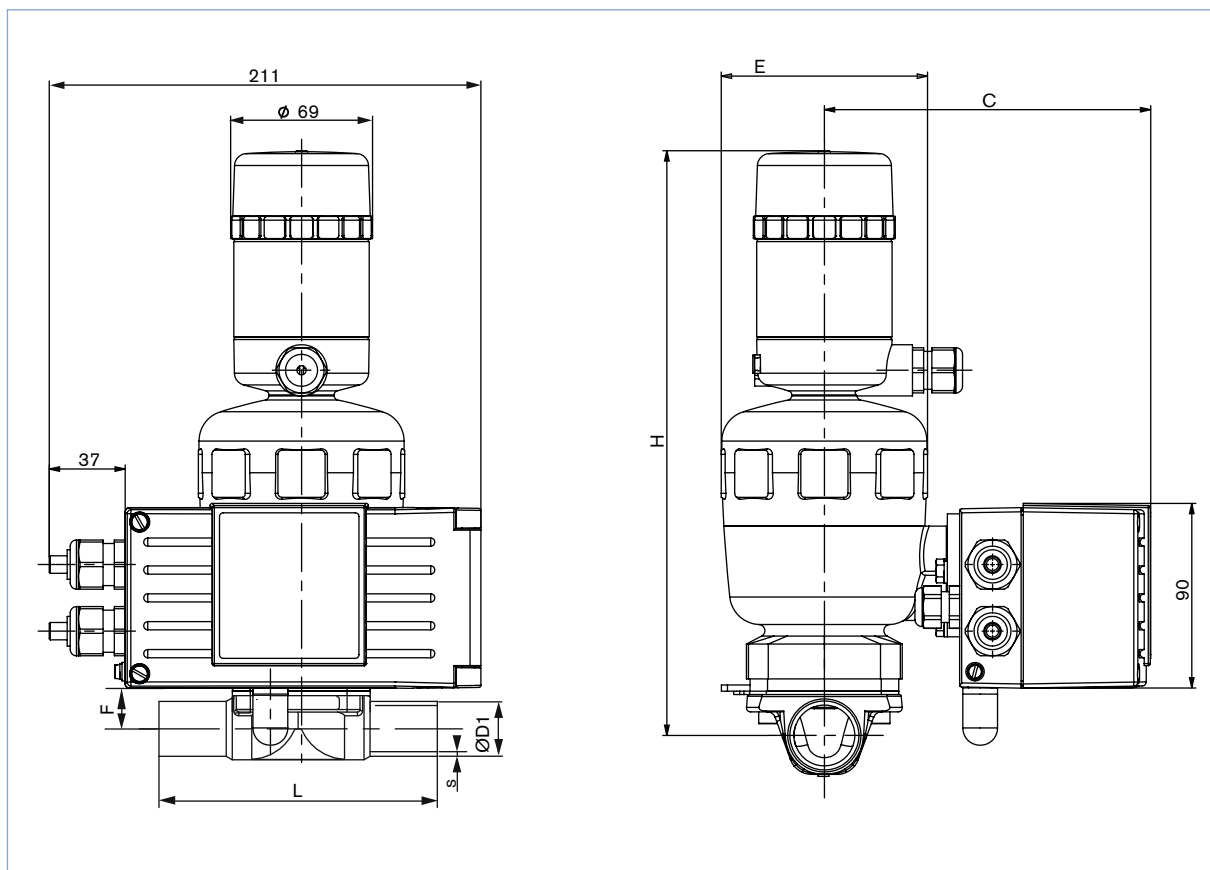

Port connection [mm]	Actuator size [mm]	E	H	F	C	L	EN ISO 1127/ ISO 4200		DIN 11850								SMS 3008		JIS (on request)	
							D1	s	Series 0		Series 1		Series 2		Series 3		D1	s	D1	s
									D1	s	D1	s	D1	s	D1	s				
15	80	101	262	14	159	110	21.3	1.6	18	1.5	18	1	19	1.5	20	2	-	-	21.7	2.1
20	80	101	267	18	159	119	26.9	1.6	22	1.5	22	1	23	1.5	24	2	-	-	27.2	2.1
25	80	101	270	23	159	129	33.7	2	28	1.5	28	1	29	1.5	30	2	25	1.2	25.4	1.2
40	125	153	366	50	185	161	48.3	2	40	1.5	40	1	41	1.5	42	2	38	1.2	38.1	1.2
50	125	153	372	54	185	192	60.3	2	52	1.5	52	1	53	1.5	54	2	51	1.2	50.8	1.5

Dimensions for valve system Continuous CLASSIC Type 8802-DD [mm], *continued*

Dimensions valve system Continuous CLASSIC 8802-DD-P with Positioner SideControl Remote Type 8792 and Type 8802-DD-Q with Process Controller SideControl Remote Type 8793 [mm]

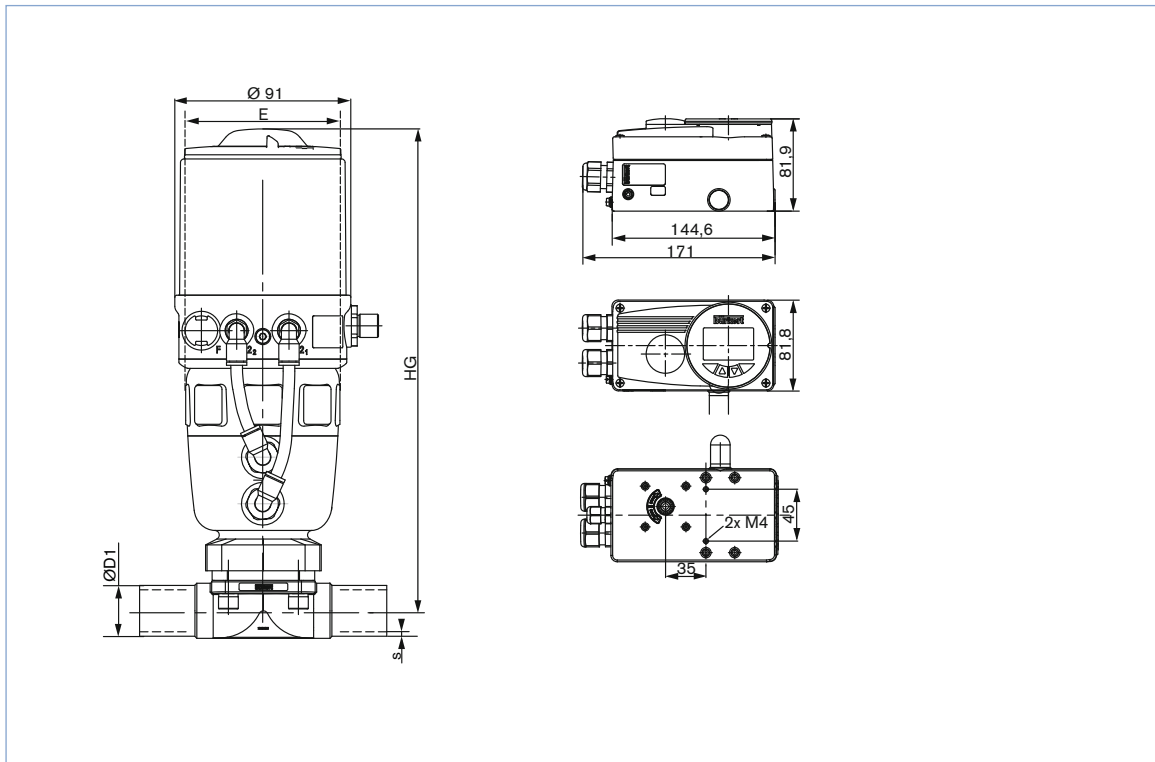

Port connection [mm]	Actuator size [mm]	E	HG [mm]	L	EN ISO 1127/ ISO 4200		DIN 11850								SMS 3008		JIS (on request)	
					D1	s	Series 0		Series 1		Series 2		Series 3		D1	s	D1	s
							D1	s	D1	s	D1	s	D1	s				
15	80	101	263	110	21.3	1.6	18	1.5	18	1	19	1.5	20	2	-	-	21.7	2.1
20	80	101	273	119	26.9	1.6	22	1.5	22	1	23	1.5	24	2	-	-	27.2	2.1
25	80	101	276	129	33.7	2	28	1.5	28	1	29	1.5	30	2	25	1.2	25.4	1.2
40	125	153	369	161	48.3	2	40	1.5	40	1	41	1.5	42	2	38	1.2	38.1	1.2
50	125	153	375	192	60.3	2	52	1.5	52	1	53	1.5	54	2	51	1.2	50.8	1.5

Note

You can fill out the fields directly in the PDF file before printing out the form.

Valve system Continuous CLASSIC Type 8802-DD - Request for quotation

Please fill out and send to your nearest Bürkert facility* with your inquiry or order

Company	Contact person
Customer no.	Department
Address	Tel./Fax
Postcode/town	E-Mail

= mandatory fields to fill out

Quantity

Required delivery date

Operating data

Pipeline DN PN

Pipe material

Process medium

Type of media Liquid Steam Gas

min standard max unit

Flow rate (Q, Q_N, W) ¹⁾

Temperature at valve inlet

Absolute pressure at valve inlet

¹⁾ standard unit: Liquid Q = m³/h; Steam W = kg/h; Gas Q_N = Nm³/h

Valve features

Specification key

automatically transferred from last page [go to page](#)

<input type="checkbox"/>	<input type="checkbox"/>	<input type="checkbox"/>	<input type="checkbox"/>	<input type="checkbox"/>	<input type="checkbox"/>	<input type="checkbox"/>	<input type="checkbox"/>
--------------------------	--------------------------	--------------------------	--------------------------	--------------------------	--------------------------	--------------------------	--------------------------

Surface finish (if not standard) internal μm external μm

Pilot pressure min. max.

Continued on next page →

Valve system Continuous CLASSIC Type 8802-DD - Request for quotation, *continued*

Control unit features	
<input type="checkbox"/> Positioner TopControl Type 8692 More info.	<input type="checkbox"/> Process Controller TopControl Type 8693 More info.
<p>Pneumatic function</p> <input type="checkbox"/> Single-acting <input type="checkbox"/> Double-acting <p>Communication</p> <input type="checkbox"/> Profibus <input type="checkbox"/> DeviceNet <p>Electrical connection</p> <input type="checkbox"/> Cable gland <input type="checkbox"/> Multipol connection <p>Feedback</p> <input type="checkbox"/> 4-20 mA <input type="checkbox"/> 4-20 mA + 2 binary outputs <p>Initiator</p> <input type="checkbox"/> Initiator <p>Please specify item no. if known:</p> <input style="width: 100%;" type="text"/>	<input type="checkbox"/> Positioner TopControl Basic Type 8694 More info.
<p>Pneumatic function</p> <input type="checkbox"/> Single-acting <p>Pilot air ports:</p> <input type="checkbox"/> Push-in connector external ø 6 mm or 1/4" <input type="checkbox"/> Thread G 1/8" <p>Electrical connection</p> <input type="checkbox"/> Cable gland <input type="checkbox"/> Multipol connection <p>Feedback</p> <input type="checkbox"/> 4-20 mA <p>Please specify item no. if known:</p> <input style="width: 100%;" type="text"/>	<p>Pneumatic function</p> <input type="checkbox"/> Single-acting <p>Pilot air ports:</p> <input type="checkbox"/> Push-in connector external ø 6 mm or 1/4" <input type="checkbox"/> Thread G 1/8" <p>Electrical connection</p> <input type="checkbox"/> Cable gland <input type="checkbox"/> Multipol connection <p>Feedback</p> <input type="checkbox"/> 4-20 mA <p>Please specify item no. if known:</p> <input style="width: 100%;" type="text"/>

Control unit features	
<input type="checkbox"/> Positioner SideControl Remote Type 8792 More info.	<input type="checkbox"/> Process Controller Side-Control Remote Type 8793 More info.
<p>Power supply 24 VDC</p> <p>Communication</p> <input type="checkbox"/> without <input type="checkbox"/> Profibus DPV1 <p>Feedback</p> <input type="checkbox"/> Analogue feedback + 2 binary outputs <input type="checkbox"/> 2 binary outputs <p>Electrical connection</p> <input type="checkbox"/> Cable gland <input type="checkbox"/> Multipol connection <p>Please specify item no. if known:</p> <input style="width: 100%;" type="text"/>	<input type="checkbox"/> Positioner SideControl Type 8635 – 2-wire More info.
<p>Power supply 24 VDC</p> <p>Communication</p> <input type="checkbox"/> without <input type="checkbox"/> Profibus DPV1 <p>Feedback</p> <input type="checkbox"/> Analogue feedback + 2 binary outputs <input type="checkbox"/> 2 binary outputs <p>Electrical connection</p> <input type="checkbox"/> Cable gland <input type="checkbox"/> Multipol connection <p>Please specify item no. if known:</p> <input style="width: 100%;" type="text"/>	<p><input type="checkbox"/> Standard</p> <p><input type="checkbox"/> ATEX/FM Zone 1</p> <p><input type="checkbox"/> Zone 2/22</p> <p>Power supply 24 VDC via Setpoint or BUS</p> <p>Communication Setpoint / feedback analogue signal or via BUS <input type="checkbox"/> Profibus PA</p> <p><input type="checkbox"/> Positioner version Input 4–20 mA Feedback <input type="checkbox"/> 4–20 mA <i>or/and</i> <input type="checkbox"/> Binary</p> <p><input type="checkbox"/> PID Controller version ³⁾ Input measuring signal 4–20 mA</p> <p>Inductive proximity switch</p> <input type="checkbox"/> 1 <input type="checkbox"/> 2 <p>Please specify item no. if known:</p> <input style="width: 100%;" type="text"/>

³⁾ same setpoint for input and feedback signal as for Positioner version

Certifications
<input type="checkbox"/> Attestation of compliance with the order EN-ISO 10204 2.1 (Item-No. 440 788) <input type="checkbox"/> Test report EN-ISO 10204 2.2 (Item-No. 803 722) <input type="checkbox"/> Certification of Conformity for Raw Material EN-ISO 10204 3.1 (Item-No. 803 723) <input type="checkbox"/> EN161 (European Gas Device guideline) <input type="checkbox"/> FDA - USP certificate

Comments

Valve features, specification key

Example

A 15 AB VG SA42 C F NO06

Specification key

Please make a choice

CONTROL FUNCTION

A	normally closed by spring action
B	normally open by spring action
I	double acting

ORIFICE [mm] (Diaphragm size)

15
20
25
32
40
50

SEAL MATERIAL

AB	EPDM in food quality
AD	EPDM
EA	PTFE/EPDM
FF	FKM
EU	advanced PTFE/EPDM in two pieces

BODY MATERIAL

VG	Cast stainless steel 316L/1.4435
----	----------------------------------

VARIABLE CODES

Surface finish, internal		
NO06	int. mechanical polished Ra=0.8 µm	Standard
NO16	int. electro polished Ra=0.6 µm	

ACTUATOR SIZE ¹⁾

F	ø 80 mm
G	ø 100 mm
H	ø 125 mm

¹⁾ see technical data on p. 2

ACTUATOR MATERIAL

C	PA	Standard
D	PPS	



PORT CONNECTION

Port connection weld end

Port conn. [mm]	EN ISO 1127/ISO 4200	SMS 3008	DIN 11850				BS 4825	ASME BPE	JIS Sanitary	JIS Utility
			Series 0	Series 1	Series 2	Series 3				
15	SA42=21.3x1.6		SC43=18x1.5	SF41=18x1.0	SD42=19x1.5	SE42=20x2.0	SODD=12.7x1.2	SA92=12.7x1.65	SA72=21.7x2.1	
20	SA43=26.9x1.6		SC44=22x1.5	SF42=22x1.0	SD43=23x1.5	SE43=24x2.0	SODE=19.05x1.2	SA93=19.05x1.65	SA76=27.2x2.1	SA80=27.2x2.1
25	SA44=33.7x2.0	SA60=25.0x1.2	SC45=28x1.5	SF43=28x1.0	SD44=29x1.5	SE44=30x2.0	SODF=25.4x1.65	SODF=25.4x1.65	SA73=25.4x1.2	SA81=34x2.0
32	SA45=42.4x2.0		SC46=34x1.5	SF44=34x1.0	SD45=35x1.5	SE45=36x2.0				SA83=42.7x2.0
40	SA46=48.3x2.0	SA62=38.0x1.2	SC47=40x1.5	SF45=40x1.0	SD46=41x1.5	SE46=42x2.0	SODH=38.1x1.65	SODH=38.1x1.65	SA74=38.1x1.2	SA84=60.5x2.0
50	SA47=60.3x2.0	SA63=51.0x1.2	SC48=52x1.5	SF46=52x1.0	SD47=53x1.5	SE47=54x2.0	SODI=50.8x1.65	SODI=50.8x1.65	SA75=50.8x1.5	

Clamp

Port conn. [mm]	ISO 2852 SMS 3017	BS4825	DIN 32676
	15	TC42=Clamp 34 - for tube ISO 4200	TH43=Clamp 25 - Tube 19.05x1.2
20	TC43=Clamp 50.5 - for tube ISO 4200		TD43=Clamp 34 - Tube 23x1.5
25	TC44=Clamp 50.5 - for tube ISO 4200	TG44=Clamp 50.5 - Tube 25.4x1.65	TD44=Clamp 50.5 - Tube 29x1.5
40	TC46=Clamp 64 - for tube ISO 4200	TG45=Clamp 50.5 - Tube 38.1x1.65	TD46=Clamp 50.5 - Tube 41x1.5
50	TC47=Clamp 77.5 - for tube ISO 4200	TG46=Clamp 64 - Tube 50.8x1.65	TD47=Clamp 64 - Tube 53x1.5

*To find your nearest Bürkert facility, click on the orange box →

www.burkert.com

In case of special application conditions, please consult for advice.

Subject to alteration.
© Christian Bürkert GmbH & Co. KG

1510/12_EU-en_00891908